

INTRODUCTION TO ECONOGRAPHICATION

By

Mario Arturo Ruiz Estrada*

The rationale of Econographication revolves around the efficacy of graphs as the most effective analytical tool for visualization of any economic phenomena. The main motivation behind the creation of Econographication is to evaluate graphs evolved so far in economics and to develop new types of graphs to facilitate the study of economics, as well as finance and business. Thereby, the mission of Econographication is to offer academics, researchers and policy maker's alternative analytical tool in the research and teaching-learning process of economics, Finance and business.

The theoretical framework of Econographication draws very much on graphs designs: soft graphs design and hard graphs design. In addition, the research involved is supported by three types of graphs: analytical graphs, descriptive graphs and graphs simulations.

At the inception of Econographication, the following new types of graphs and Cartesian Spaces are presented: Pyramid Graph Cartesian Space (PG) and Diamond Cartesian Space (DG), Multi-Dimensional Cartesian Space (MD), Infinity Cartesian Space (I-Cartesian Space) and Multi-functional Cartesian Space (MF). These Cartesian Spaces are constructed based on the traditional 3-Dimensional space concept, but they represent 4-D, 5-D, 8-D, 9-D and Infinity-Dimension. The multiple-dimensional representations are to facilitate easy understanding of economic phenomena from a general view.

Keywords: Econographication, economic methods, econometrics, economics teaching and methodology

* The author is a lecturer at INPUMA, University of Malaya (UM). Kuala Lumpur, Malaysia.
Tel. Number: +60126850293.
E-mail: Marioruiz@um.edu.my and Mario-ruiz@econographication.com
Homepage: www.econographication.com

1. Evolution of the Application of Graphs in Economics

In the evolution of the application of graphs in economics, so far two systems of Cartesian planes have been used: basic analytical Cartesian plane system based on 2-Dimensions and complex analytical Cartesian plane system under 3-Dimensions. The basic analytical Cartesian plane system was first used in the XIX century. It started with Antoine Augustin Cournot's work, where mathematics began to be used in Economics. Basic analytical graph system consists of Utility Theory, General Equilibrium, Optimal of Pareto, Partial Equilibrium and Indifference Curves. These graphs were introduced by innovator economists William Stanley Jevons, Leon Walras, Vilfredo Pareto, Alfred Marshall and Francis Ysidro Edgeworth respectively. (McClelland, 1975)

The complex analytical Cartesian plane system has its origin in the XX century. It started with the introduction of sophisticated mathematics techniques in the development of new economic models. Calculus, trigonometry, geometry, statistical methods and forecasting methods are used in these graphs. 3-Dimensional graphs are also part of the complex analytical Cartesian plane system and are applied in economic research. (Ovondo-Bodino, 1967)

The rapid development of complex analytical Cartesian plane system was facilitated by high technology and sophisticated instruments of analysis such as the electronic calculator and the computer. The development of the instruments of analysis in economics took place in two stages. The first stage involved the "Basic Computational Instruments", where electronic calculators were used to compute basic mathematical expressions (e.g. long arithmetic operations, logarithm, exponents and squares). This took place between the 1950's and 1960's.

The second stage of development took place in the middle of the 1980's. This is when high speed and high storage computers with sophisticated software were first used. Called "High Computational Instruments", such sophisticated software enables easy information management, application of difficult simulations as well as the creation of high resolution under 3-D graphs. These instruments contributed substantially to the development and research of economics. Each of the Basic Analytical Space System and Complex Analytical Cartesian plane System can be categorized according to functions or dimensions. In terms of functions, the Cartesian planes are either descriptive or analytical. In terms of dimensions, the graph can be either 2-D or 3-D.

In descriptive graphs, arbitrary information is used to observe the effect of theories. Analytical graph, on the other hand are time-series graphs, cross-section graphs and scatter diagrams. In analytical graphs, statistical data is used to show trends and relationships between two or more variables. However, the analytical graphs are supported by the application of high computational instruments based on sophisticated hardware and software.

Based on 100 papers (100%) published in recognized 21 economic journals¹ between 1940's and 2004 (JSTOR, 2004), it is observed that the common types of graphs applied in the study of social sciences, especially in economics are the 2-Dimensional graphs. We find that the 98% of the papers in study is used 2-D graphs. And only 2% of the papers in study are applied 3-D graphs. However, this research is interested to present a new type of Cartesian Spaces: Multi-dimensional Cartesian Space (MD), Infinity Cartesian Space (I-Cartesian Space) and Multi-Functional Cartesian Space. It enables economists to analyze economic phenomena from multiple perspectives and facets in time and space.

2. Econographication Theoretical Framework

The Econographication is originated for the necessity to generate an alternative and specialized analytical tool in economics focused on the specific study of uses and design of graphs. Therefore, the general objective of Econographication is to maximize the uses of graphs to minimize difficulties in the process of research and teaching-learning of economics and other issues related to economics such as business, management and finance.

The Econographication is defined as an analytical tool that involves the study of the evolution of graphs applied in economics, design of new graphs and finally the application of new graphs in economics, as well as finance and business. This new analytical tool will be facilitator to understand any economic phenomena from the graphical point of view. The Econographication theoretical framework is divided into three large sections are analytical graphs, descriptive graphs and graphs simulations. The analytical graphs can use real data or experimental data under micro-level and macro-level of analysis in the short and long run (See Diagram 1).

The descriptive graphs are used two types data, there are real data under micro and macro-level analysis in the short and long run, and experimental data, in the case of experimental data is divided into two large sections are diagrams and graphs. The experimental data can be two dimensional (2-D), three Dimensional (3-D) and Multi-dimensional Cartesian Spaces under Micro-level and Macro-level analysis in the short and long run analysis (see table 1 and graph 3). The last section is the graphs simulations, it is divided in two sections are electronic and prototypes. In the case of the electronic area is based on the application and uses of software and solutions (See diagram 1). The idea to include prototypes in the graphs simulations in the study of economics is to facilitate the easy understanding in the teaching-learning-research process of any economic phenomenon (See Diagram 1).

¹ American Economic Review, Canadian Journal of Economics, Econometrica, Economic History Review, Economic Journal, International Economic Review, Journal of Economic History, Journal of Economic Literature, Journal of Political Economy, Oxford Economic Papers, Quarterly Journal of Economics, Review of Economic Studies, Review of Economics and Statistics, Canadian Journal of Economics and Political Science, Journal of Economic Abstracts, Contributions to Canadian Economics, Journal of Labor Economics, Journal of Applied Econometrics, Journal of Economic Perspectives, Publications of the American Economic Association, Brookings Papers on Economic Activity, Microeconomics and American Economic Association Quarterly

**Diagram 1
Econographication Structure**

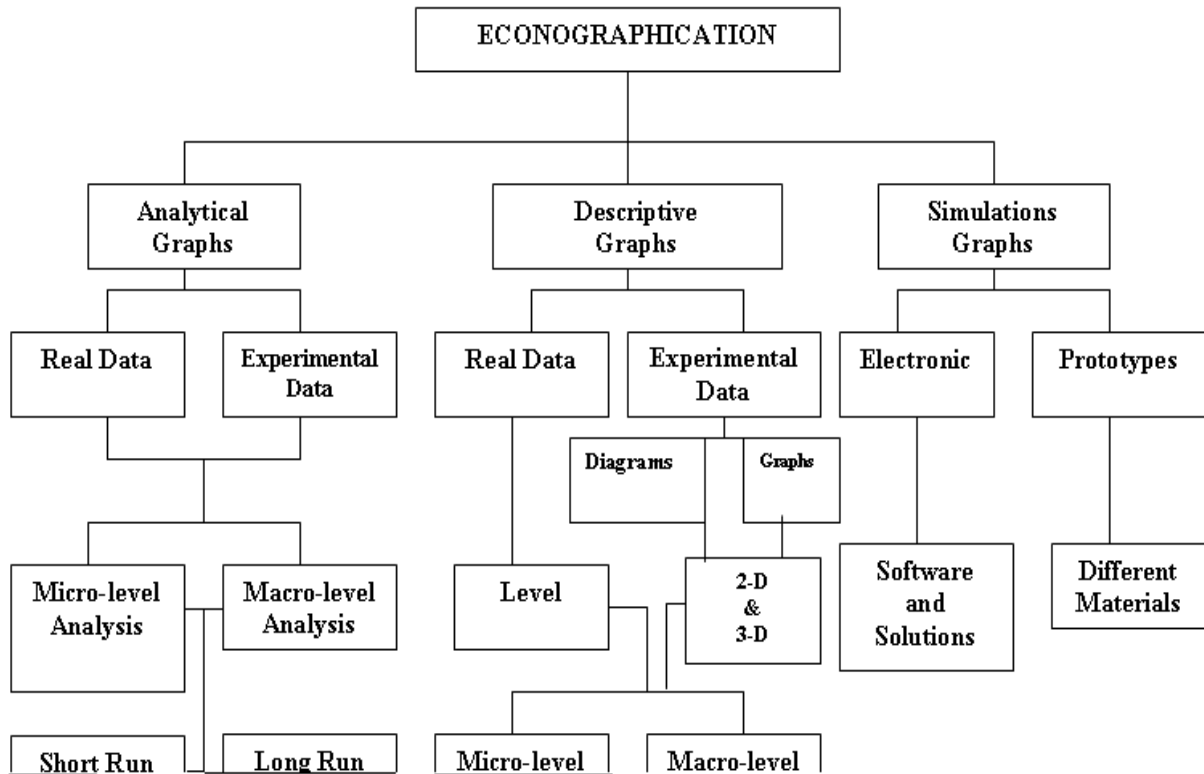

Source: designed by the author

3. New Cartesian Spaces in Economics

In this part of our research is important to mention that the 2-Dimensional graphs are not being able to show the relationship of several variables in the same time and space. The 2-Dimensional graphs can only show the relationship between one independent variable “x” and one dependent variable “y”. The relationship between “x” and “y” can be observed clearly by the function $y=f(x)$. However, in our opinion the 3-Dimensional space can open the possibility to build the construction of new types of graphs and Cartesian spaces in different dimensions such as 4-Dimensional, 5-Dimensional, 8-Dimensional, 9-Dimensional and Infinity-Dimensional. The new types of Cartesian Spaces will be presented by Econographication is the Pyramidal Cartesian Space, Diamond Cartesian Space, Multi-Dimensional Cartesian Space (MD), Infinity Cartesian Space (I-Cartesian Space) and Multi-Functional Cartesian Space (MF) (See Table 1).

3. Introduction of New Cartesian Spaces in Economics

3.1. The Pyramidal Cartesian Space (PG)

The pyramidal Cartesian Space consists of five axes ($[x_1, x_2, x_3, x_4], y$), representing four independent variables " x_1 ", " x_2 ", " x_3 " and " x_4 " and one dependent variable " y " respectively. Each " x " variable (x_1, x_2, x_3, x_4) and " y " variable has its individual axis. Representing the dependent variable, the fifth axis, " y " is positioned in the center of the graph (among the other four axes). " y " has a positive value. It is the convergent point of all the other four axes x_1, x_2, x_3 and x_4 . In other words, all " x_i " axes converge at the " y " axis. In this type of graph only work with positive values into its Cartesian Space.

In the case of pyramidal Cartesian Space all variables " x_i " and " y " are either on the positive side of respective axes together. In other words, if all or some " x_i " change, then the value of " y " can be modified any time. Therefore, we have two possible scenarios: first scenario, if all or some x_i move from outside to inside, then " y " move down. Second scenario, if all or some x_i move from inside to outside, then " y " move up. Therefore, any change in some or all " x_i " will affect " y " directly. (See Graph 1 and Prototype 1) (See Ruiz, 2004 and 2004.a). The function to be used by the pyramid Cartesian Space is following by:

$$y = f(x_1, x_2, x_3, x_4)$$

Graph 1
The Pyramid Cartesian Space

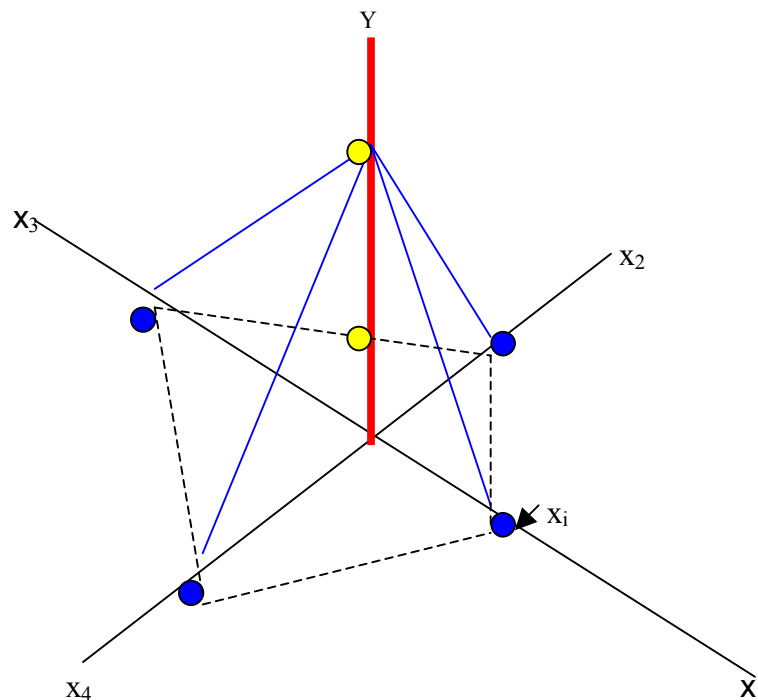

Prototype 1
The Pyramid Cartesian Space Prototype

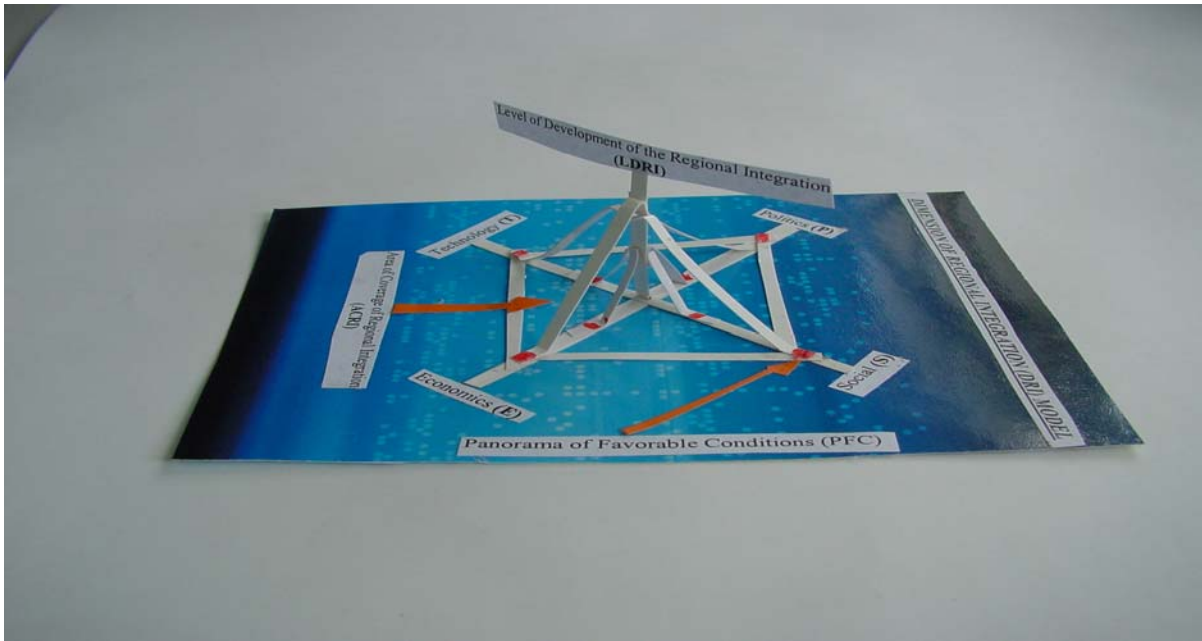

Source: designed by the author

3.2. Diamond Cartesian Space (DG)

In Diamond Cartesian Space (DG) design is based on the 3-D Cartesian Space. The Diamond Cartesian Space has two levels of analysis. Each level of analysis is represented by $L_j = ([x_{ji}], y_j)$; "j" represent the level of analysis (in our case can be level one "L₁" or level two "L₂") and "i" represent the allocation of each "x_i". Here is important to mention that the first level has five axes represented by $L_1 = ([x_{11}, x_{12}, x_{13}, x_{14}], y_1)$, four independent variables "x₁₁", "x₁₂", "x₁₃" and "x₁₄" and one dependent variable "y₁" respectively. The second level of analysis is represented by $L_2 = ([x_{21}, x_{22}, x_{23}, x_{24}], y_2)$. We assume that between level one "L₁" of analysis and level two "L₂" of analysis non-exist inter-dependency, the common issue between these two levels of analysis is that both levels are used the same axes in "x_i" in the Cartesian Space. However, level one "L₁" of analysis cannot affect the level two "L₂" of analysis. And level two "L₂" of analysis also cannot affect the level one "L₁" of analysis. If we draw both different level of analysis in the Cartesian Space then we can compare two different scenarios in the same Cartesian Space to visualize two different scenarios at the same time (See Graph 2). Something important to mention is that the fifth and sixth axis (y₁ and y₂) is positioned in the center of the Cartesian Space (among the other four "x_i"). We assume that both "y" or (y₁, y₂) use only positive values. The final result, if we join the two levels of analysis, then we can observe a figure represented by a diamond (See Ruiz, 2005.a). The Functions to be applied in the Diamond Cartesian Space, there are:

$$Y_1 = f(X_{11}, X_{12}, X_{13}, X_{14})$$

$$Y_2 = f(X_{21}, X_{22}, X_{23}, X_{24})$$

**Graph 2
Diamond Cartesian Space (DG)**

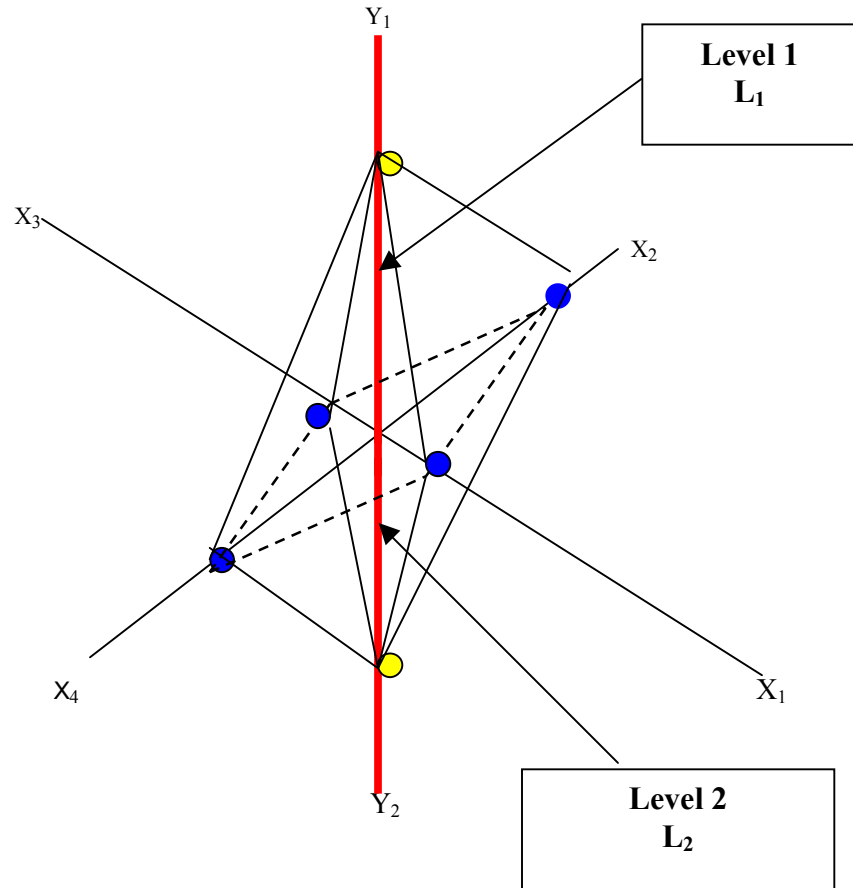

Source: designed by the author

3.3. Multi-Dimensional Cartesian Space (MD)

In MD Cartesian Space, this Cartesian Space consists of five axes ($[x_1, x_2, x_3, x_4, y]$), representing four independent variables “ x_1 ”, “ x_2 ”, “ x_3 ” and “ x_4 ” and one dependent variable “ y ” respectively. Each “ x ” variable (x_1, x_2, x_3, x_4) and “ y ” variable has its individual axis that is a vertical line with both positive and negative values. The positive and negative values are represented by ($[x_1, -x_1], [x_2, -x_2], [x_3, -x_3], [x_4, -x_4], [y, -y]$) on the MD Cartesian Space.

In the case of 2-D and 3-D Graphs and Cartesian Spaces, the individual variables can be anywhere along the vertical and horizontal axes; but in the case of MD Cartesian Space all variables (x_i) and the “ y ” variable are either on the positive side of respective axes together on the negative side of their respective axes together. In other words, the values “ y ” can only move in its axis. Therefore, any change in some or all “ x_i ” will affect “ y ” directly. (See Graph 3 and Prototype 2)

Representing the dependent variable, the fifth axis, “y” is positioned in the center of the graph (among the other four axes). “y” has a positive value and negative value. It is the convergent point of all the other four axes x_1 , x_2 , x_3 and x_4 . In other words, all “ x_i ” axes converge at the “y” axis. The result is a figure represented by a pyramid that can be reshaped into two cubes or one cube (See Ruiz, 2005). The function to be used by the Multi-Dimensional Cartesian Space is equal to $Y = f(x_1, x_2, x_3, x_4)$.

3.4. Comparison of 2-D, 3-D Cartesian Plane and MD Cartesian Space

The traditional 2-D and 3-D Graphs and Cartesian Spaces are not being able to show the relationship of several variables in the same space and time. 2-D Graph and Cartesian Space shows the relationship between one dependent variable “x” and one independent variable “y”. 3-D Graphs and Cartesian plane (x, y, z) shows the relationship between two independent variables (x, y) and one dependent variable is “z”. MD Cartesian Space with its five axes ($[(x_1, x_2, x_3, x_4), y]$) however, shows the relationship between four independent variables ($[(x_1, -x_1), (x_2, -x_2), (x_3, -x_3), (x_4, -x_4)]$) simultaneously and one dependent variable ($x, -x$). The main objective of the Multi-Dimensional Cartesian Space is to show any economic phenomena from a general perspective (See Table 1).

Table 1
Difference between 2-D, 3-D and 3-D Cartesian Space

DIMENSION	AXIS	VARIABLES	FUNCTION
2-Dimensional Cartesian Space 2-D	2 Axes (x,y)	1 dependent (y) 1 independent (x)	$y = f(x)$
3-Dimensional Cartesian Space 3-D	3 Axes (x,y,z)	1 dependent (z) 2 independent (x,y)	$z = f(x,y)$
Multi-Dimensional Cartesian Space MD	5 Axes ([x ₁ ,x ₂ ,x ₃ ,x ₄],y)	1 dependent (y) 4 independent (x ₁ ,x ₂ ,x ₃ ,x ₄)	$y = f(x_1, x_2, x_3, x_4)$
Infinity Cartesian Space ID	n axes ([x ₁ ,x ₂ ...x _{n+1}], [y _{n+1}])	n dependent (y ₁ ,y ₂ ,...y _n) n independent (x ₁ ,x ₂ ,...x _n)	$y = f(x_1, x_2, x_3... x_n)$ n=1.....+∞
Multi-Functional Cartesian Space MF	9 Axes $R_1 = A_i(x_{ij}, y_{000})$ & $R_2 = A_i(x_{ij}, y_{0ij})$	5 dependent (y ₁ , y ₂y ₅) 8 independent (x ₁ ,x ₂x ₈)	Ratio 1 $y_{000} = f(x_{11}, x_{21}, x_{31}, x_{41})$ Ratio 2 $y_{011} = f(x_{12})$ $y_{021} = f(x_{22})$ $y_{031} = f(x_{32})$ $y_{041} = f(x_{42})$

Source: Designed by the author

Graph 3
The 2-D, 3-D and MD Cartesian Space

(a.) 2-D Cartesian Plane

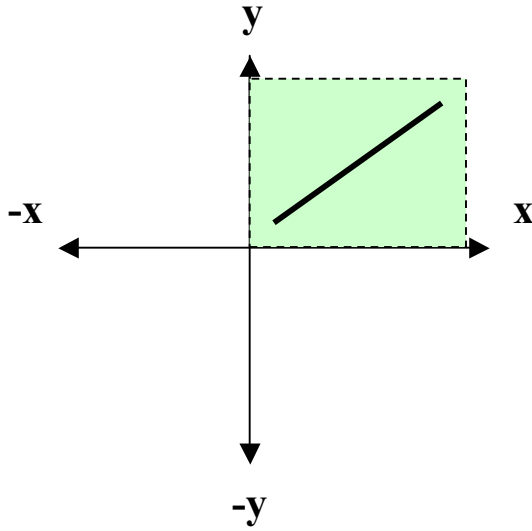

(b.) 3-D Cartesian Plane

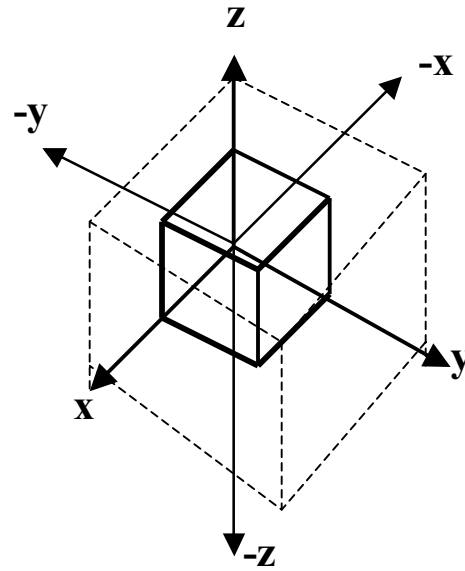

(c.) MD Cartesian Space

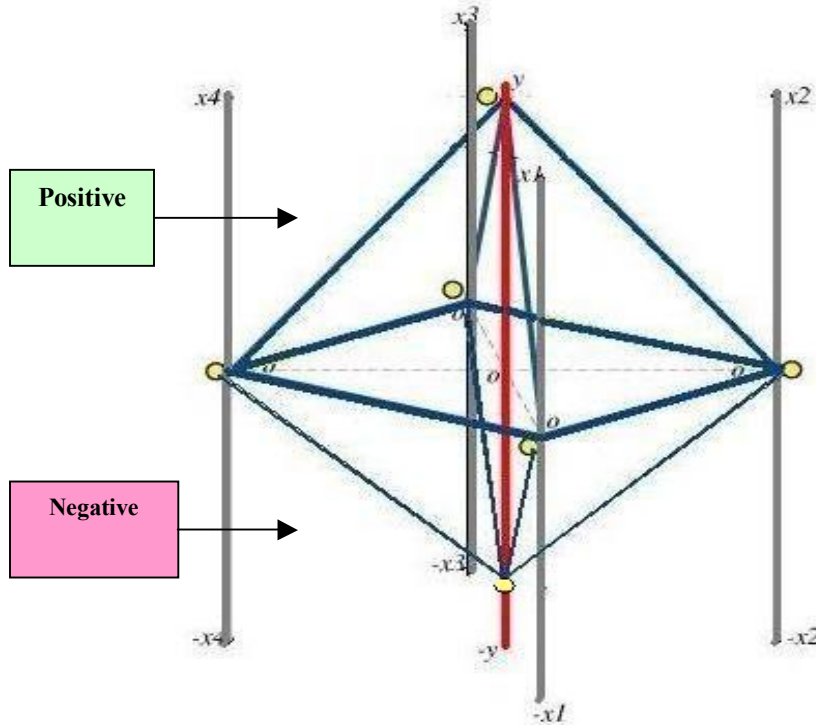

Source: Designed by the author

Prototype 2
The Multi-Dimensional Cartesian Space (MD) Prototype

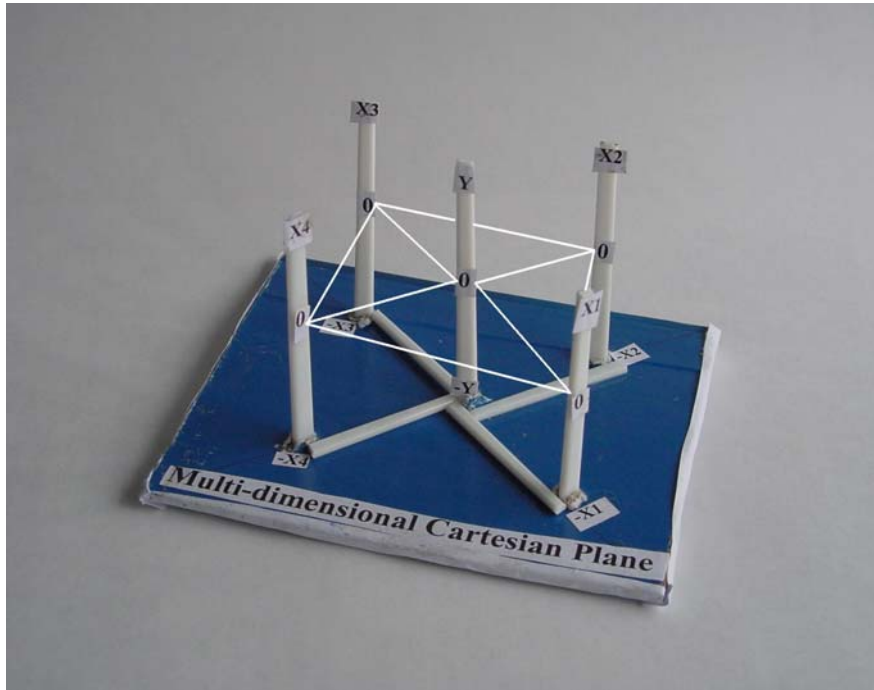

Source: designed by the author

3.5. Infinity Cartesian Space (I-Cartesian Space)

The Infinity Cartesian Space (I-Cartesian Space) will be an alternative Cartesian Space to visualize different type of graphs from different perspective. The I-Cartesian Space is formed by n independent variables ($x_1, x_2, x_3 \dots x_n; n = 1 \dots +\infty$) and one dependent variable that is “ y ”. But “ y ” can have positive and negative values. The new modality of “ y ” is that this variable can be located in different positions into the circle parametric of the infinity Cartesian Space. The circle parametric is formed by join all x_i ($x_1, x_2, x_3 \dots x_n$) until to create a cylinder. We assume that “ y ” has high mobility into the circle parametric. The position of “ y ” in the circle parametric is depends on the analysis we are interested to develop or demonstrate. We can observe that the final graph is a cylinder with different levels of dimension in the time and space. The graphs in the infinity Cartesian Space can generate different figures, but the analysis of this type of graphs is based on the criteria of the researcher and application interested to demonstrate (See Graph 4 and Prototype 3). The Function of the infinity Cartesian Space is follow by $y = f(x_1, x_2, x_3 \dots x_n); n = 1 \dots +\infty$

Characteristics:

1. Researchers can input any quantity of dependent variables in the Cartesian Space.
2. The dependent variable (y) can be located in different positions into the Cartesian Space.

3. The generation of new type of graphs in different dimensions in the time and space.

Graph 4
The Infinity Cartesian Space (I-Cartesian Space)

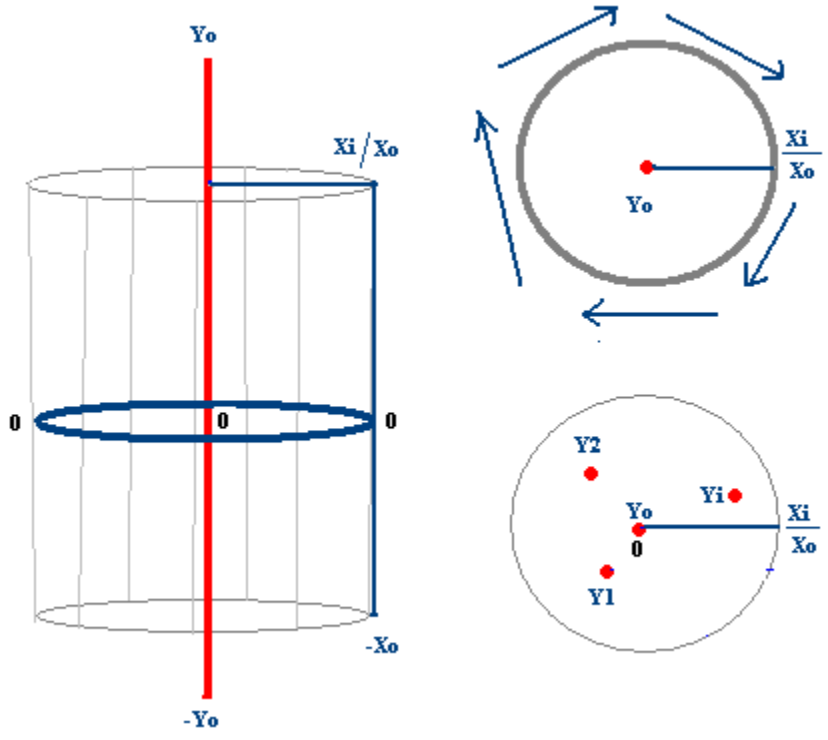

Source: designed by the author

Prototype 3
The Infinity Cartesian Space (I-Cartesian Space) prototype

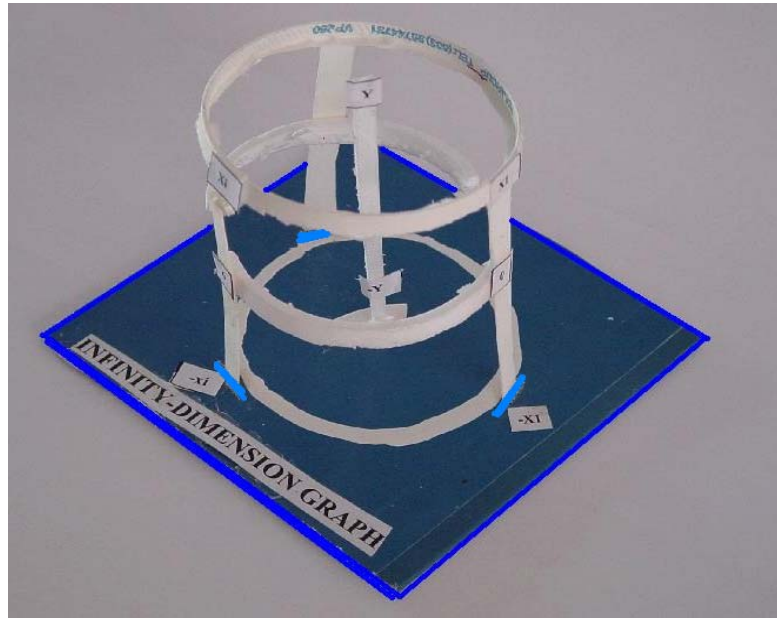

Source: designed by the author

3.6. Multi-Functional Cartesian Space (MF)

The multi-functional (MF) Cartesian Space has nine general axis are $[(x_{1i}, x_{2i}, x_{3i}, x_{4i}), (y_{000}, y_{01i}, y_{02i}, y_{03i}, y_{04i})]$. In the same Cartesian plane is also formed by two ratios of analysis, there are Ratio 1 (R_1) and Ratio 2 (R_2). Each Ratio "R" has four spaces (or quadrants). The R_1 function is equal to (x_{ij}, y_{000}) and R_2 function is equal to (x_{ij}, y_{0ij}) , where "i" has values from 1 to 4 and "j" has values from 1 to ∞ . The four spaces of R_1 spaces are $S_I = (x_{11}, y_{000})$; $S_{II} = (x_{21}, y_{000})$; $S_{III} = (x_{31}, y_{000})$; $S_{IV} = (x_{41}, y_{000})$ and the four spaces of R_2 spaces are $S_V = (x_{12}, y_{011})$; $S_{VI} = (x_{22}, y_{021})$; $S_{VII} = (x_{32}, y_{031})$; $S_{VIII} = (x_{42}, y_{041})$. The MF Ratios have strong relationship between the two levels R_1 and R_2 , for example first relationship between R_1 and R_2 is $[S_I = (x_{11}, y_{000}) : S_V = (x_{12}, y_{011})]$. The second relationship between R_1 and R_2 is $[S_{II} = (x_{21}, y_{000}) : S_{VI} = (x_{22}, y_{021})]$. The third relationship between R_1 and R_2 is $[S_{III} = (x_{31}, y_{000}) : S_{VII} = (x_{32}, y_{031})]$. The last relationship between R_1 and R_2 is $[S_{IV} = (x_{41}, y_{000}) : S_{VIII} = (x_{42}, y_{041})]$ (See Graph 5 and Prototype 4.) In the case of R_1 has four axis or independent variables are " $x_{11}, x_{21}, x_{31}, x_{41}$ " and one y-axis or one dependent variable that is equal to " y_{000} ". The " y_{000} " can be share by the four independent variables $[x_{11}, x_{21}, x_{31}$ and $x_{41}]$. Therefore, the R_1 function is equal to $A_i(x_{i1}, y_{000})$. The Difference between R_1 and R_2 is that R_2 has four x-axis or four independent variables ($x_{12}, x_{22}, x_{32}, x_{42}$) and four y-axis or four dependent variables ($y_{011}, y_{021}, y_{031}, y_{041}$).

RATIO I : RATIO II

$$\begin{aligned}
 S_I &= (x_{11}, y_{000}) : S_V = (x_{12}, y_{011}) \\
 S_{II} &= (x_{21}, y_{000}) : S_{VI} = (x_{22}, y_{021}) \\
 S_{III} &= (x_{31}, y_{000}) : S_{VII} = (x_{32}, y_{031}) \\
 S_{IV} &= (x_{41}, y_{000}) : S_{VIII} = (x_{42}, y_{041})
 \end{aligned}$$

The functions are used by the Multi-Functional Cartesian Space, there are:

Ratio 1

$$y_{000} = f(x_{11}, x_{21}, x_{31}, x_{41})$$

Ratio 2

$$y_{011} = f(x_{12})$$

$$y_{021} = f(x_{22})$$

$$y_{031} = f(x_{32})$$

$$y_{041} = f(x_{42})$$

Characteristics:

1. Researchers can input eight independent variables and five dependent variables in the same Cartesian Space simultaneously.
2. The analysis of different scenarios in the same space and time. We can observe clearly how any change of all or some independent variable can affect all Cartesian Space from a general view.

Prototype 4: The Multi-Functional Cartesian Space

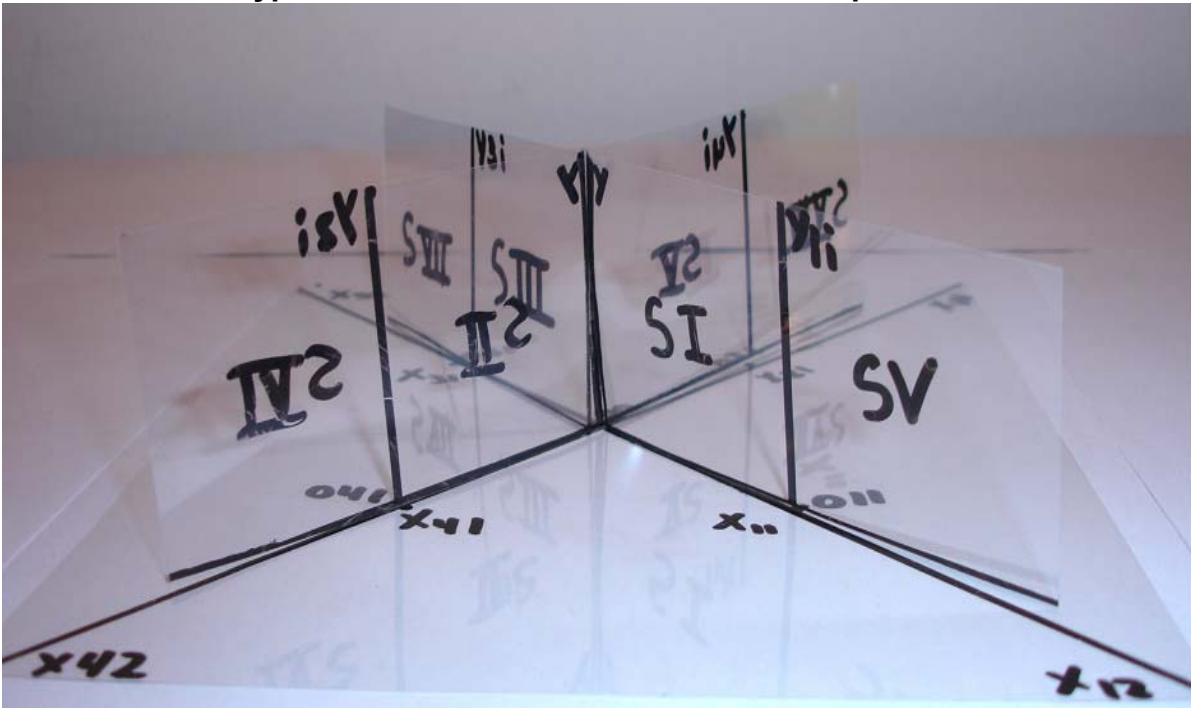

Source: designed by the author

Graph 5
The Multi-Functional Cartesian Space

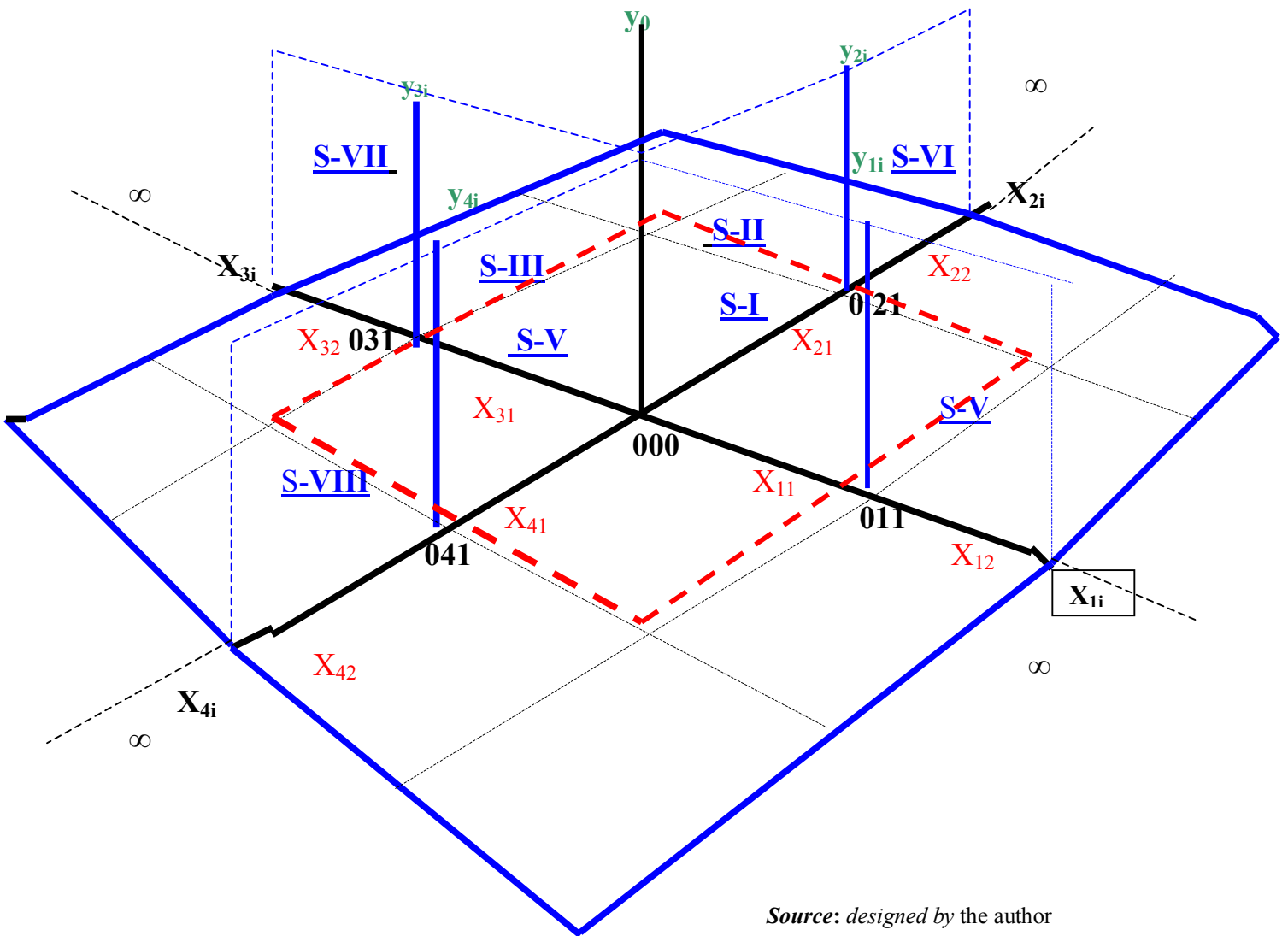

▭ Ratio I ▭ Ration II

4. Conclusion

The Econographication attempts to be an analytical tool focus to support the study of economics, as well as finance and business. The main idea to build Econographication is to offer a new analytical tool or technique that can facilitate the study of any economic, finance and business phenomena under macro-level and micro-level of analysis in the short and long run. In summation, the Econographication also will play important role in the research and teaching-learning process of economics through a series of new graphs methods and techniques that can be used by academics, researchers, economist and policy makers.

5. Acknowledgment

I am particularly thankful to:

God and Jesus
My Parents and Family

6. References

Avondo-Bodino, G. (1963) "Economic Applications of the Theory of Graphs", Gordon & Breach Publishing Group, January 1963, pp. 126

Beineke W. L. (1989) "Are Graphs Finally Surfacing?", The College Mathematics Journal, Vol. 20, No.3, pp. 2106-225

JSTOR (2004) "Journals in Economics Section": www.jstor.org, Economics Section, date: August, 2004

McClelland, P. (1975) "Causal Explanation and Model Building in History, Economics, and the New Economic History", Cornell University Press, pp. 296

Royston, E. (1956) "Studies in the History of Probability and Statistics: III. A Note on the history of the graphical Presentation of Data", Biometrika, Vol. 43, No. ¾, pp. 241-247

Ruiz, M. A. (2004) "The Global Dimension of Regional Integration (GDRI) Model", FEA-Working Paper No. 2004-7, pp. 1-42

————— (2004.a) "The Trade Liberalization Evaluation (TLE) Methodology", Journal of Policy Modeling, Vol. 26 No. 8-9, pp. 1015-1030

Ruiz, M. A. (2005) "New Visual Perspective for Economic Analysis: The Multi-Dimension (MD) Cartesian Plane", FEA-Working Paper No.2005-1, pp.1-10

————— (2005.a) "The Openness Growth Monitoring (OGM) Model, Journal of Policy Modeling, Economic Note, Vol. 28 (Forthcoming)